

TWT[®] PRODUCT PACKAGING



All products & systems are:

- Properly packaged, skidded and /or crated to ensure safe delivery
- Shipped complete with all components ready for easy installation*
- Provided with easy to follow installation & application guidelines
- Clearly numbered for easy inventory and stockroom control



Skidded

Crated



Packaged



*Pumps, piping, fittings, valves, and other material needed to and from system owners responsibility





70 Kinderkamack Road, Suite 102 ■ Emerson, New Jersey 07630 ■ USA
201-576-0400 ■ Fax 201-576-0410 ■ 1-800-728-3420 ■ E-Mail: info@triangularwave.com

HOW TO ORDER

By Order Form:

This is the best way. To place an order, just make a copy of the Purchase Order form you'll find on the next page of this document, fill in all appropriate information and submit it to Triangular Wave Technologies, Inc. In-house/company purchase order forms may be submitted. Review TWT sales order form for appropriate contents.

By e-mail:

Download our Purchase Order form you'll find on the next page of this document, or you will find it in the Contact Us Section of the website. In-house/company purchase order forms may be submitted. Review TWT sales order form for appropriate contents.

By Mail:

Mail Purchase Order form TWT / In-House to Triangular Wave Technologies, Inc at:
70 Kinderkamack Rd • Emerson, New Jersey, 07630 • USA
You can use our order form and mail it, or you can just mail the product item number, prices, credit card info. etc.

By Fax:

You can use TWT or In-House Purchase Order form and fax it, or you can just fax the product item number, prices, credit card info. etc. Initialed and/or signed by an authorized representative.
Fax to Triangular Wave Technologies, Inc. to: 201-576-0410.

By Phone:

We do not accept phone-in orders. You may call in your credit card number if you are concerned about **internet security**. Please call Triangular Wave Technologies, Inc. at **1-800-728-3420 USA • 201-576-0400 Overseas**

How to Pay:

We accept Visa, MasterCard, Discover Card and American Express. We also accept payment by company check or direct wire transfer (contact TWT, Inc. prior to payment for additional details) .

Delivery:

Allow one to two weeks for in stock products and/or systems. Custom engineered, integrated systems, special order(s) three to five weeks. Delivery for high volume purchase orders will be established on a case by case bases.

Upon receipt of purchase order from customer(s), TWT, Inc. will review, process, contact if necessary and confirmation will be sent to customer(s) for final approval.

Request a Quote:

Go to home page of TWT website and click on "Request Quote" banner top of page. Follow instructions and fill in all pertinent information



All Orders FOB Company Warehouses

DISCOUNTS: Available upon request for volume purchasers on a case by case basis

PURCHASE ORDER FORM

Triangular Wave Technologies, Inc.
70 Kinderkamack Road
Emerson, New Jersey, 07630, USA

Tel: 1-800-728-3420 USA • 201-576-0400 overseas

Fax: 201-576-0410 • E-mail: info@triangularwave.com

Bill To: _____ Address: _____ City: _____ State: _____ Zip: _____ Country: _____ Phone: _____ Fax: _____ Auth. Sig. _____ E-mail _____ Resale Certificate# _____ <small>(Please mail signed copy to Triangular Wave Technologies, Inc.)</small>	Ship To: _____ Address: _____ City: _____ State: _____ Zip: _____ Country: _____ Phone: _____ Fax: _____ Attn: Dept./Loc: _____ <small>ALL ORDERS SUBJECT TO CREDIT APPROVAL AND PRODUCT AVAILABILITY. PRICES SUBJECT TO CHANGE AT ANY TIME WITHOUT NOTICE. PRODUCTS ARE SOLD AT PRICES IN EFFECT AT THE TIME OF ORDER, ACCORDING TO THE TWT TERMS, CONDITIONS AND PRICE SCHEDULE.</small> <small>ALL TAXES, DUTIES, INSURANCE AND FREIGHT CHARGES ARE THE RESPONSIBILITY OF THE CUSTOMER</small>
--	---

Account# _____ **Country:** _____ **Installation Location:** _____

Phone: _____ **Fax:** _____ **E-mail:** _____

***Payment Method:** Check Money Order enclosed **Corporate PO# (attach copy if avail.)** _____

Credit Card: Visa MC Amex DC Discover JCB Cards Other _____ **Card#** _____ **Exp:** __/__/__

Order Date: __/__/__ **Requested Ship Date:** __/__/__ **Ship Via:** _____

TWT Model#	Description	Quantity	Price U.S. Dollars	Total

Special Instructions <div style="height: 40px;"></div>	<table border="1" style="width: 100%; border-collapse: collapse;"> <tr> <td style="padding: 2px;">Sub-Total</td> <td style="padding: 2px;"> </td> </tr> <tr> <td style="padding: 2px;">Processing, Shipping and Handling</td> <td style="padding: 2px;">TBD**</td> </tr> <tr> <td style="padding: 2px;">Sales Tax</td> <td style="padding: 2px;">TBD</td> </tr> <tr> <td style="padding: 2px;">Total</td> <td style="padding: 2px;"> </td> </tr> </table>	Sub-Total		Processing, Shipping and Handling	TBD**	Sales Tax	TBD	Total	
Sub-Total									
Processing, Shipping and Handling	TBD**								
Sales Tax	TBD								
Total									

* For payment procedures from outside the USA, please contact Triangular Wave Technologies, Inc. for details.
Prices are F.O.B. company warehouse(s) and will be shipped least expensive way unless otherwise requested. Freight & Insurance charges will appear on invoice.

**TBD: Carriers shipping and handling costs for products are constantly changing. For that reason, it is difficult for TWT to determine the exact shipping method, weight and charges for products before TWT has a confirmed and excepted purchase order in-house.

Triangular Wave Technologies, Inc

Purchase Order Review

Triangular Wave Technologies, Inc. products and systems provide technologically advanced methods for water and fluid management that are both efficient and cost-effective. Components and subsystems chosen from across the range of treatment methods can be combined in different configurations to provide custom solutions specific to any industry, site or application.

Each product line offers a variety of both standalone and comprehensive treatment solutions for end-to-end fluid management, for all types of applications.

To ensure the greatest level of satisfaction in your work with the TWT®, Fluid Management Products & Systems

- Know the performance capabilities and technical limitations of all products and systems to guarantee the proper installation application and treatment solutions.
- Manage Customer/End-User Expectations: Verify the purchase order product/system application, installation and performance needs, customer/end-user perceptions and manage all expectations.

Take these steps before placing your purchase order

Triangular Wave Technologies Deposit Control Systems:

1. Verify the pipes/tubes to be treated in your systems, *i.e., diameter of pipe or Tube (1", 2", 3", etc.) pipe material – copper, PVC, steel, ductile iron, glass, rubber, etc.*
2. Verify that you have chosen the correct location and application method, *i.e., determine reaction zones, onsite solenoid wrap, Copper Pipe Signal Enhancer, Reaction Chamber, etc.*
3. Verify that you have determined the appropriate Deposit Controller based on water quality review, system to be treated (process review); check your installation & technical guidelines packet, catalog and/or TWT website for additional information.
4. If any upgrades/changes are requested, it must be noted on your purchase order, *e.g., voltage source changes (110/240 etc.), Deposit Controller upgrades and reason for upgrade additional wire & type of wire (Teflon, etc.), Reaction Chamber construction material e.g., Schedule 40/80 PVC, etc.*
5. When using TWT Deposit Control Systems in conjunction with or integrated within other TWT or non TWT treatment technologies and systems, be certain to verify the performance capabilities and technical limitations of all system components.

Triangular Wave Technologies Filtration, Ultraviolet and Integrated Systems:

1. Before purchasing TWT filtration, ultraviolet and/or TWT integrated systems, be certain to *verify* the industry-specific application, installation and performance capabilities of these products and systems.
2. TWT Inc. recommends that all filtration, ultraviolet and TWT integrated systems, be sold and/or purchased with an initial supply of replacement products *e.g., replacement filters, UV lamps etc.* This will insure uninterrupted service and treatment.

If not completely sure of the products performance capabilities, intend use and application will meet your expectations, email TWT Inc. at info@triangularwave.com for further assistance.

Review the TWT catalog, CD and/or visit TWT website for additional technical support, if needed.
Allow enough time for purchase order review, product development, shipping & handling.
We thank you and look forward to a mutually beneficial and advantageous relationship



Email: info@triangularwave.com • www.Triangularwave.com



TWT PRODUCTS TERMS AND CONDITIONS/USA

ORDER PROCESSING:

2 weeks minimum

BLANKET ORDERS:

Accepted with the time period not to exceed six (6) months from date of original purchase order.

SHIPPING AND HANDLING:

All shipments F.O.B. TWT company warehouse(s). Shipments will be sent out the least expensive way (generally UPS) unless otherwise requested by customer. Large orders which exceed the size limitations of UPS will generally be sent via common carrier.

All products will be properly packaged, skidded or crated, and ready for shipping. If necessary, TWT will assist Purchaser to arrange shipping from F.O.B. point of origin to Purchaser's point of destination.

DELIVERY:

Contact TWT for specific information regarding ship time for orders. Most products require two to six weeks from date of order to delivery. Please allow sufficient time for delivery unless other arrangements have been made.

TWT shall not be liable for any failure or delay in furnishing the equipment, material or labor resulting from fire, explosion, flood, storm, Act of God, Government acts / orders / regulations, hostilities, civil disturbances, strikes, labor difficulties, delay of carrier, non-delivery of parts by the manufacturer or other causes beyond its control.

PAYMENT TERMS

Other than advanced payment, all orders are C.O.D. unless you have an established account with us. If you wish to open an account, please contact us for a credit application. Terms are Net 30 days from invoice date. A service charge of 1 1/2 % will be assessed monthly to all accounts which have an outstanding balance after 30 days. All past due accounts are automatically put on C.O.D. until the account is brought current.

NOTICES:

TWT makes no warranty of merchantability or fitness for a particular purpose other than as described in TWT Owner's Manual. All equipment or products referenced herein are subject to availability and to be discontinued by TWT without notice. Should specific models become unavailable, TWT reserves the right to substitute functionally equivalent TWT models and/or configurations for those models discontinued.

RETURNS:

No returns will be accepted without written return authorization from TWT and according to TWT return policy.

TAXES:

All orders subject to applicable sales tax unless a valid resale certificate is furnished. Prices do not include taxes. Consequently, the amount of any present or future sales, use, excise or other applicable tax to the sale of the products shall be paid by the Purchaser unless a properly executed tax exemption certificate acceptable to the tax authorities is provided. Purchaser is responsible for remittance of all applicable taxes.

ALL PURCHASE ORDERS:

TWT reserves the right to accept or reject any order. Orders received, acknowledged, and accepted by TWT are considered firm and non-cancelable. Changes made to orders by Purchaser may be subject to price adjustments. Custom orders and orders designed specifically for Purchaser cannot be cancelled once the construction material has been ordered and/or production has begun. Any requested cancellations will incur the price of materials ordered and design and manufacturing time spent up to that time.

PRICES:

Subject to change at any time without notice. Products are sold at prices in effect at the time of order, according to the TWT price schedule.

IN-TRANSIT DAMAGE:

TWT cannot be held liable for equipment damaged, container shortages, or shipments lost by freight carrier. Shipments should be inspected for visible damage at time of delivery, and carrier's receipt or Bill of Lading should be noted "Internal Condition Unknown" before Consignee signs acceptance of delivery. All in-transit damage claims should be placed immediately with the carrier's claims representative.

DISCOUNTS:

Available upon request for volume purchasers on a case by case basis. -Minimum Order - Case Pack

Note: Review TWT catalog, website and/or product sheets for detailed technical information.

We accept Visa, MasterCard, Discover Card and American Express. We also accept payment by company check or direct wire transfer.

Although Triangular Wave Technologies, Inc. has attempted to ensure the accuracy of the content of this publication, and its website, it is possible that they may contain technical inaccuracies, typographical, or other errors. Triangular Wave Technologies, Inc. assumes no liability for any error in its publications, and for damages, whether direct, indirect, incidental, consequential or otherwise.

Triangular Wave Technologies, Inc. provides these publications "as they are" without warranty of any kind, either express or implied, but not limited to implied warranties of merchantability or fitness for a particular purpose.

The published information in the publication and on the website are subject to change without notice. Triangular Wave Technologies, Inc. reserves the right to make changes in the products, systems, design and layout without notification to its customers.



TWT PRODUCTS TERMS AND CONDITIONS/EXPORT

ORDER PROCESSING:

2 weeks minimum

BLANKET ORDERS:

Accepted with the time period not to exceed six (6) months from date of original purchase order.

SHIPPING & HANDLING:

All shipments (F.O.B.) from company warehouses. All products will be properly packaged, skidded, or crated, and ready for shipping. If necessary, TWT will assist Purchaser to arrange shipping from F.O.B. point of origin to Purchaser's point of destination. International orders must be freight prepaid before order is released.

DELIVERY:

2-6 weeks after receiving payment. Contact TWT for specific information regarding ship time for orders. Most products require four to six weeks from date of order to delivery. Please allow sufficient time for delivery unless other arrangements have been made.

TWT shall not be liable for any failure or delay in furnishing the equipment, material or labor resulting from fire, explosion, flood, storm, Act of God, Government acts / orders / regulations, hostilities, civil disturbances, strikes, labor difficulties, delay of carrier, non-delivery of parts by the manufacturer or other causes beyond its control.

PAYMENT TERMS:

All payments must be by wire transfer in advance, or by irrevocable, transferable, confirmed letter of credit (In a US bank and in US dollars only).

NOTICES:

TWT makes no warranty of merchantability or fitness for a particular purpose other than as described in TWT Owner's Manual. All equipment or products referenced herein are subject to availability and to be discontinued by TWT without notice. Should specific models become unavailable, TWT reserves the right to substitute functionally equivalent TWT models and/or configurations for those models discontinued.

PAYABLE TO:

Triangular Wave Technologies, Inc. / Bank / Acct# / Routing# (Info. available at time of purchase)

TAXES:

Prices do not include taxes. Consequently, the amount of any present or future sales, use, excise or other applicable tax to the sale of the products shall be paid by the Purchaser unless a properly executed tax exemption certificate acceptable to the tax authorities is provided.

ALL PURCHASE ORDERS:

TWT reserves the right to accept or reject any order. Orders received, acknowledged, and accepted by TWT are considered firm and non-cancelable. Changes made to orders by Purchaser may be subject to price adjustments. Custom orders and orders designed specifically for Purchaser cannot be cancelled once the construction material has been ordered and/or production has begun. Any requested cancellations will incur the price of materials ordered and design and manufacturing time spent up to that time.

PRICES:

Subject to change at any time without notice. Products are sold at prices in effect at the time of order, according to the TWT price schedule.

IN-TRANSIT DAMAGE:

TWT cannot be held liable for equipment damaged, container shortages, or shipments lost by freight carrier. Shipments should be inspected for visible damage at time of delivery, and carrier's receipt or Bill of Lading should be noted "Internal Condition Unknown" before Consignee signs acceptance of delivery. All in-transit damage claims should be placed immediately with the carrier's claims representative.

RETURNS:

No returns will be accepted without written return authorization from TWT and according to TWT return policy.

DISCOUNTS:

Available upon request for volume purchasers on a case by case basis. -Minimum Order - Case Pack Note: Review TWT catalog, website and/or product sheets for detailed technical information.

We accept Visa, MasterCard, Discover Card and American Express. We also accept payment by company check or direct wire transfer.

Although Triangular Wave Technologies, Inc. has attempted to ensure the accuracy of the content of this publication, and its website, it is possible that they may contain technical inaccuracies, typographical, or other errors. Triangular Wave Technologies, Inc. assumes no liability for any error in its publications, and for damages, whether direct, indirect, incidental, consequential or otherwise.

Triangular Wave Technologies, Inc. provides these publications "as they are" without warranty of any kind, either express or implied, but not limited to implied warranties of merchantability or fitness for a particular purpose.

The published information in the publication and on the website are subject to change without notice. Triangular Wave Technologies, Inc. reserves the right to make changes in the products, systems, design and layout without notification to its customers.



Product Warranty

All components of the Triangular Wave Microprocessor Deposit Control Systems are covered by a Five (5) Year Warranty provided that:

1. No modifications are performed on the unit;
2. The system is installed as recommended by Triangular Wave Technologies, Inc. and
3. There is no modification or change of installation without prior consultation with Triangular Wave Technologies, Inc. or its agents.

In the unlikely event that the unit becomes non-functioning, e.g., the “power” light and/or the “coil energized” light are not receiving the signal & are not lit, please return the unit for replacement to the place of purchase, with proof of purchase information.*

The Triangular Wave System does not affect the potability or the natural mineral content of the water, as there is no direct contact with the water. Triangular Wave Technologies, Inc., therefore, accepts no responsibility for water quality.

Performance Warranty (90 days)

Triangular Wave Technologies, Inc. warrants that the Triangular Wave Microprocessor Deposit Control System will perform as indicated in this Owner’s/ Installation Manual. If the product does not perform as indicated, the unit may be returned within 90 days from the invoice date for a full refund of the purchase price, less the direct cost of shipping and installation.* Customer agrees that Triangular Wave Technologies, Inc. or its agents will be given access to the equipment for 90 days in order to monitor its performance, if desired, and/or to inspect the product and installation prior to any requested return authorization.

Under no circumstances shall Triangular Wave Technologies, Inc. or its agents be liable for consequential, special, contingent damages, claims or other demands in excess of the purchase price of the unit.

The Deposit Control System is non-invasive and non-chemical by design, and is suitable for nearly all applications requiring hard water treatment. The treatment process does not add anything to the fluid and should not cause damage to piping or equipment. The Deposit Control System is designed to remove scale; if piping or equipment has suffered corrosion prior to the installation of a TWT Deposit Control System, the removal of this scale may potentially reveal cracks/pin holes in this piping or equipment that had been held together by this scale. If structural damage or corrosion is suspected to exist, appropriate measures should be taken to alleviate this condition prior to or in conjunction with the installation of the TWT Deposit Controller. Equipment owners must continue to be responsible in standard infrastructure and equipment maintenance procedures as recommended by the manufacturers of all piping and fluid fed equipment.

Triangular Wave Microprocessor Deposit Control System components should be inspected, upon receipt, for damage that might occur during shipment. The carrier and Triangular Wave Technologies, Inc. or its agents must be notified immediately if damage is found.** With proper care during installation and maintenance, the system will provide faithful service for many years.

**Triangular Wave Technologies, Inc. or its Authorized Representatives must be notified prior to any return for the proper Return Authorization, conditions and procedures.*

***With the exception of Triangular Wave Technologies, Inc. represented products / components, which are covered by a separate standard warranty indicated in the products’ Owners Installation Manual provided.*

Triangular Wave Technologies, Inc. provides total support before, during, and after the installation.



TWT® DEPOSIT CONTROLLER TERMINAL HOOKUP & APPLICATION GUIDELINES

The TWT® Deposit Control System will give many years of service if installed properly. Please read all instructions carefully (owners installation manual) before assembling the system.

The unit is provided with a line cord. The cord should remain unplugged until the installation is complete. Mount the unit to a supporting structure using the base mounting flange, and case mounting kit supplied. Install two mounting feet to the top rear of controller case with screws supplied. Place one of the mounting brackets on the top corner over the locating tab on each side of the unit, attach the brackets with screws provided. The two bottom mounting holes are located inside the controller in the terminal hookup area. You need to remove the front panel to locate the mounting holes at the bottom corners of the case. With the brackets in place you have a method to fasten all four corners of the controller to an appropriate surface.

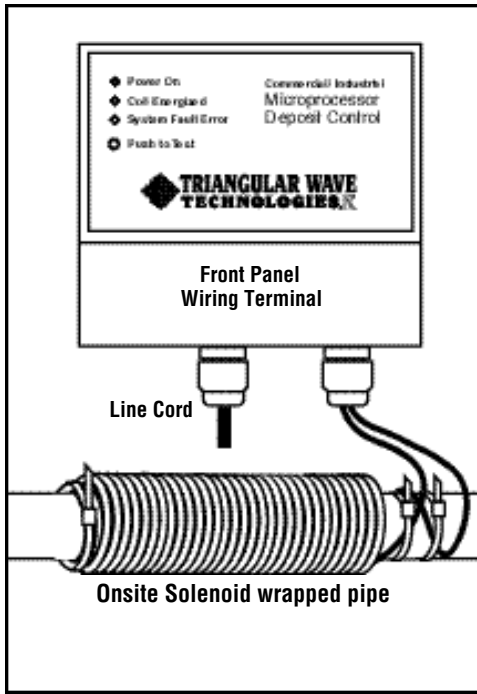

TWT-CSE Copper Pipe Signal Enhancer Application

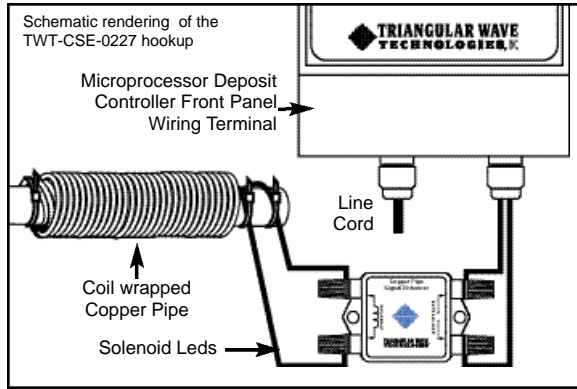

Copper pipes, although acceptable, are one of the more difficult of materials to work with. To overcome this...

TWT has developed its Copper Pipe Signal Enhancer. This unit is placed between the Deposit Controller and the solenoid coil on the copper pipe as illustrated. The function of the signal enhancer is to provide a proper impedance match and to ensure maximum energy transfer between the controller and the solenoid, which, in turn, ensures enhanced treatment of the fluid.

Special Note:
Copper pipe signal enhancers are to be used on copper pipes only.

TWT Deposit Controller terminal Hookup

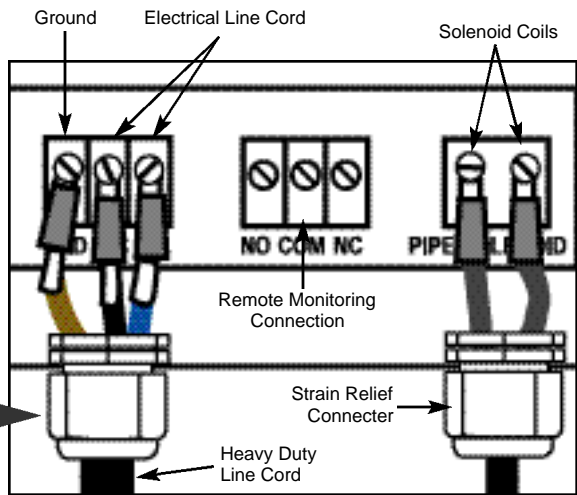
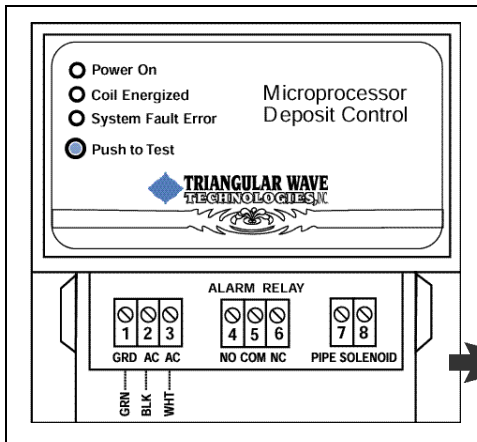

TWT Deposit Control Unit

The controller is supplied with a wiring kit and a strain relief connector for the solenoid coil wires. This strain relief will provide a water resistant seal for the two coil wires. You should rotate the compression ring counter clockwise to release pressure on the seal. Feed the two wires through the provided holes and tighten the compression ring. Connect the two wires to the coil terminals in the controller housing as illustrated (refer to winding instructions in owners installation manual). A standard installation will not require access to the main control circuit board, because all connections are available in the wiring terminal. The control circuit is accessed by removing the front panel of the TWT unit.

Factory Wrapped Wire Coil Reaction Chambers Application

- To address magnetic pipe applications
- When a protected environment (code) is needed
- When on-site solenoid wrap is not applicable

The TWT Reaction Chamber is part of the patented TWT Deposit Control Technology. The Reaction Chamber provides a chamber through which the water flows and is exposed to the triangular wave signal that lies at the heart of the deposit control technology. As the fluid passes through, it is treated and then carries that treatment downstream, to condition the rest of the plumbing system, non-chemically and reliably.

When you have purchased a reaction chamber with cable and connectors with your controller unit, the correct strain relief connector for the controller is furnished with the cable for the reaction chamber. The strain relief connector on the controller (pipe solenoid) should be removed and replaced with the strain relief connector provided with the reaction chamber cable. The two wires should be connected to the coil terminals in the controller housing as illustrated above.

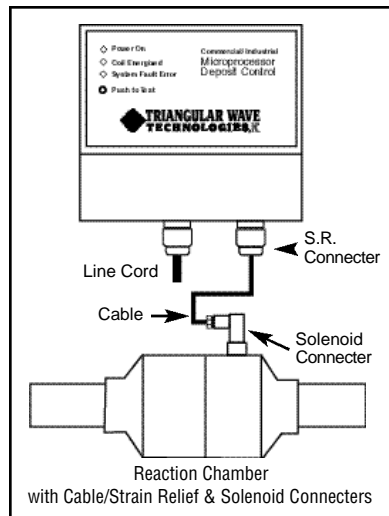

Schematic rendering of industrial reaction chamber hookup

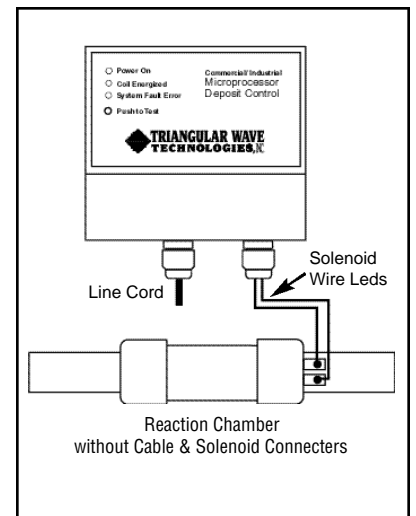

Schematic rendering of reaction chamber hookup using wiring kit provided



Product Warranty

The Triangular Wave Integrated MD/DP Treatment Systems are warranted, provided that:

1. No modifications are performed on the unit;
2. The system is installed as recommended by Triangular Wave Technologies, Inc.
3. There are no modifications or changes to installation without prior consultation with Triangular Wave Technologies, Inc. or its agents.

Warranty:

- 5 Year Warranty on Structural Components such as valves, pipes, UV chambers, filter housings, mounting boards and deposit control systems.
- 1 Year Warranty on Electronic Components.
- Consumables [UV lamps, quartz sleeves and filters] carry no warranty.

Triangular Wave Technologies, Inc. warrants that the Integrated Treatment systems will perform as indicated in their Owner's/Installation Manual. If the unit does not perform as indicated, refer to the "Trouble-Shooting Guide" and Care and Maintenance material included with your unit. If trouble persists contact your Dealer/Distributor for immediate Technical Support.

Under no circumstances shall Triangular Wave Technologies, Inc. or its agents be liable for consequential, special, or contingent damages, other claims or demands in excess of the purchase price of the unit.

The MD/DP System is non-chemical by design. The treatment process does not add anything to the fluid and should not cause damage to piping or equipment. The MD/DP System is designed to treat and condition the fluid which includes the removal of scale. If piping or equipment has suffered corrosion prior to the installation of a TWT System, the removal of this scale may potentially reveal cracks/pin holes in this piping or equipment that had been held together by this scale. If structural damage or corrosion is suspected to exist, appropriate measures should be taken to alleviate this condition prior to, or in conjunction with the installation of the TWT unit. Facility/Equipment Owners must continue to be responsible in standard infrastructure and equipment maintenance procedures as recommended by the manufacturers of all piping and fluid fed equipment.

Triangular Wave MD/DP System components should be inspected upon receipt for damage that might occur during shipment. The carrier and Triangular Wave Technologies, Inc. or its agents must be notified immediately if damage is found. With proper care during installation and maintenance, the system will provide faithful service for many years.

Triangular Wave Technologies, Inc. provides total support before, during and after the installation.





Product Warranty

The Triangular Wave Integrated MD/DP Treatment Systems are warranted, provided that:

1. No modifications are performed on the unit;
2. The system is installed as recommended by Triangular Wave Technologies, Inc.
3. There are no modifications or changes to installation without prior consultation with Triangular Wave Technologies, Inc. or its agents.

Warranty:

- 5 Year Warranty on Structural Components such as valves, pipes, UV chambers, filter housings, mounting boards and deposit control systems.
- 1 Year Warranty on Electronic Components.
- Consumables [UV lamps, quartz sleeves and filters] carry no warranty.

Triangular Wave Technologies, Inc. warrants that the Integrated Treatment systems will perform as indicated in their Owner's/Installation Manual. If the unit does not perform as indicated, refer to the "Trouble-Shooting Guide" and Care and Maintenance material included with your unit. If trouble persists contact your Dealer/Distributor for immediate Technical Support.

Under no circumstances shall Triangular Wave Technologies, Inc. or its agents be liable for consequential, special, or contingent damages, other claims or demands in excess of the purchase price of the unit.

The MD/DP System is non-chemical by design. The treatment process does not add anything to the fluid and should not cause damage to piping or equipment. The MD/DP System is designed to treat and condition the fluid which includes the removal of scale. If piping or equipment has suffered corrosion prior to the installation of a TWT System, the removal of this scale may potentially reveal cracks/pin holes in this piping or equipment that had been held together by this scale. If structural damage or corrosion is suspected to exist, appropriate measures should be taken to alleviate this condition prior to, or in conjunction with the installation of the TWT unit. Facility/Equipment Owners must continue to be responsible in standard infrastructure and equipment maintenance procedures as recommended by the manufacturers of all piping and fluid fed equipment.

Triangular Wave MD/DP System components should be inspected upon receipt for damage that might occur during shipment. The carrier and Triangular Wave Technologies, Inc. or its agents must be notified immediately if damage is found. With proper care during installation and maintenance, the system will provide faithful service for many years.

Triangular Wave Technologies, Inc. provides total support before, during and after the installation.





RETURN POLICY & AUTHORIZATION FORM

ADM14

TWT INC. RETURN POLICY

Accepting Delivery of Your (purchase order) Shipment(s)

All products shipped from our factory are carefully checked, tested, inspected and packaged before leaving our warehouse. **Shipping errors and/or damages must be reported to TWT, Inc./Distributor and to Carrier upon receipt of shipment.** This is imperative in order to perfect any claims to the carrier, and no deviation will be accepted. No returns will be accepted without a TWT, Inc. Return Authorization Number. In order to obtain an authorization number, please use the attached RAN form.

DROP SHIPMENT(S)

For Distributors requesting drop-shipments directly to their customers, please be advised that those customers must adhere to the Policy stated herein, if Distributor is to have any recourse with TWT for shipping errors and/or damaged shipments. TWT recommends that Distributors restate the TWT Return Policy as their own policy on their company letterhead in order to ensure that all parties involved are informed and have appropriate recourse.

ACCEPTING DELIVERY OF YOUR SHIPMENT(S)

There is always the possibility of either internal or external damages caused by careless handling, accident, etc., during transit by common carrier. Further, this equipment may be damaged without any apparent visible damage to the container. As a matter of prudence, TWT insures all shipped equipment for at least the replacement value, or as otherwise requested by distributor/customer. However, TWT must ask for your assistance in determining the cause and extent of any possible damages. As a TWT policy henceforth, all will be required to follow these procedures:

- A. Upon receipt of the shipment(s) and before accepting delivery, inspect the outside packaging, cartons and skids (if it is skidded.)
- B. Note any damages to the cartons, crates, skids or equipment even if it involves an innocuous hole in the box, torn bubble wrap, minor-looking dent or banged-in corners.
- C. Clearly note on the Bill of Lading any and all damages before signing the receipt and returning the bill of lading to the delivery person AND...
- D. Whether or not there is any apparent visible damages, write internal conditions unknown on the bill of landing.
- E. If products received do not match products ordered, contact TWT/Distributor immediately with purchase order number and details of discrepancy.

THIS IS IMPERATIVE IF A CLAIM IS TO BE PERFECTED.

IF ERRORS AND/OR DAMAGE OF ANY KIND ARE DISCOVERED, SAVE ALL THE PACKING MATERIAL AND ANY CHIPS OR PIECES FOUND IN THE PACKAGING FROM BROKEN EQUIPMENT. NOTIFY TWT/DISTRIBUTOR, IMMEDIATELY SO THAT TWT/DISTRIBUTOR CAN INFORM THE FREIGHT COMPANY THAT A CLAIM WILL BE MADE. (TAKE PICTURES IF POSSIBLE)

- TRIANGULAR WAVE TECHNOLOGIES, INC. AND/OR DISTRIBUTOR WILL NOT BE ABLE TO PROCESS NOR BE RESPONSIBLE FOR ANY CLAIMS FOR ANY TRANSPORTATION DAMAGES, INTERNAL OR EXTERNAL, IF NOT NOTIFIED WITHIN 24 HOURS AFTER DELIVERY.
- TRIANGULAR WAVE TECHNOLOGIES, INC. WILL NOT BE RESPONSIBLE FOR ANY MISSING ITEMS IF NOT NOTIFIED WITHIN TWO (2) BUSINESS DAYS OF DELIVERY.
- TRIANGULAR WAVE TECHNOLOGIES, INC. WILL NOT BE RESPONSIBLE FOR ANY CLAIMS UNLESS THE ABOVE IS STRICTLY ADHERED TO.

Thank you for your kind cooperation. If you have any questions, please do not hesitate to contact us.

TWT, INC. RETURN AUTHORIZATION FORM

[for Distributor/Customer use only]

For Return Authorization, Please fill out mail and/or fax to TWT, Inc.

DATE: _____/_____/_____

Triangular Wave Technologies, Inc. • 70 Kinderkamack Road • Emerson, New Jersey, 07630, USA
 Tel: 1-800-728-3420 USA • 201-576-0400 overseas • Fax: 201-576-0410 • E-mail: info@triangularwave.com

Company/Customer Name: _____ Attn: (Dept./Loc.): _____ Address: _____ City: _____ State: _____ Zip: _____ Country: _____ E-mail: _____ Tel: _____ Fax: _____ Auth. Signature: _____ (Contact Name): _____	Account#: _____ Orig. Invoice# _____ Date Shipment Received: _____ <i>Factory is not able to except any returns that are not freight prepaid</i> <i>No products may be returned that are not properly packaged with all components included</i> <i>A restocking charge of 20% may be charged to customer/distributor for all products improperly returned</i> Mark on all cartons returned: Item#(s) #of units, RMA#
---	---

Equipment Description	Item#	Quantity	Cost/Each	Special Instructions
_____	_____	_____	_____	_____
_____	_____	_____	_____	_____
_____	_____	_____	_____	_____
_____	_____	_____	_____	_____
_____	_____	_____	_____	_____

Reason For Return:
 Defective
 Damaged
 Missing Pieces
 Authorized Trial Evaluation Completed
 Other, Explain: _____

Requested Return Total Value: _____

[for TWT Inc. office use only]

- Credit will be given upon product inspection at our factory
- Products will be replaced upon receipt at our warehouse
- Dispose of products and we will credit your account
- Return authorization denied

Authorized by: _____

Date: _____

Return Authorization #: _____

Return Products To: _____

Address: _____

City: _____ State: _____ Zip: _____ USA

RMA#: _____

Date Entered/Returned to Company/Customer

DATE: _____/_____/_____

TWT Representative: _____